

LSI

LS6106

Game (slot

machine)

Feature

- * 2 key operation : KSTART,KSOUND.
- * 3.0V operating voltage
- * Slot Machine game function
- * Direct drive buzzer output
- * 1/3duty, 1/2 bias LCD format

General Description

LS6106 is a slot machine game with direct driver buzzer output. LCD format is 1/2 bias 1/3 duty. Auto-power off function.

LCD Drawing

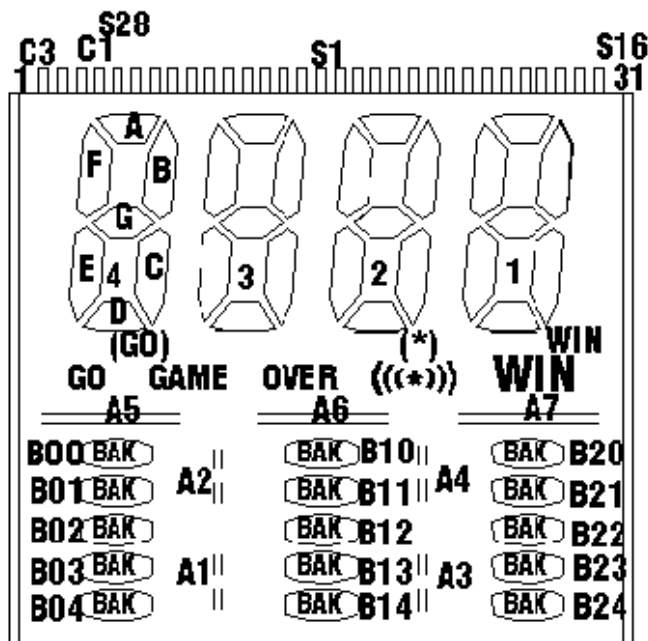

Functional Description

2 key operation

LS6106 has 2 key : KSTART , KSOUND。

Press KSTART to start the game.

Press KSOUND toggle sound ON/OFF。

Game Mode

On power up, the system has 400 marks.

Pin Assignment

DESIGNATION	TYPE	DESCRIPTION
B0, B1	OUTPUT	Buzzer output
VC1, VC2	OUTPUT	Halfer output
VEE	OUTPUT	Halfer voltage
T1, T2	INPUT	TEST pin
OO	OUTPUT	RC oscillator output
OI	INPUT	RC oscillator input
OI15P	INPUT	RC oscillator input, with 10-15pf input cap.
VDD	POWER	+3.0V power supply
GND	POWER	Ground
KSTART, KSOUND	INPUT(PH)	Input key
PB	INPUT(PH)	Power up reset
C[1:3]	OUTPUT	LCD Common output
S[1:28]	OUTPUT	LCD Segment output

Note: (PH) - pull high;

DC Characteristic

(GND = 0V, Vdd = 3.0V, Ta = 25°C)

Parameter	Symbol	Min.	Typ.	Max.	Unit	Conditions
Supply Voltage	Vdd	2.4	3.0	3.6	V	
Operating current	Idd	-	4	10	μA	No load
Oscillator Frequency	Fosc	25k	-	40k	Hz	Vdd=3.0
Buzzer output current	Ib	500	-	-	μA	Vbd-Vss=0.5
LCD frequency	Flcd	-	64	-	Hz	
Segment current	Is	0.15	-	-	μA	Vseg=0.2V
Common current	Ic	3.0	-	-	μA	Vcom=0.2V

Bonding Pad

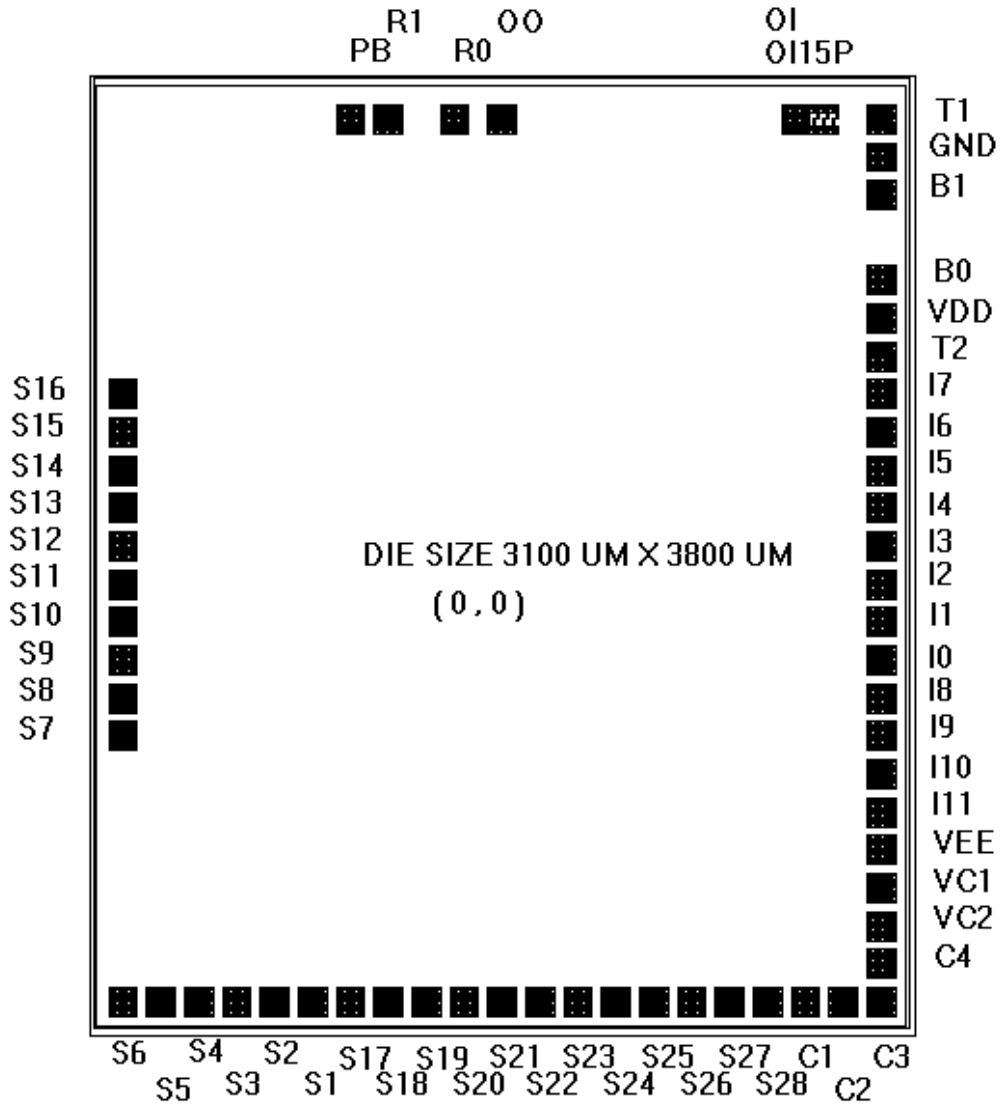

Pad location

PAD	X(μ m)	Y(μ m)	PAD	X(μ m)	Y(μ m)
S1	-724.8	-1853.0	GND	1387.0	1540.0
S2	-923.0	-1853.0	B1	1387.0	1383.0
S3	-1055.0	-1853.0	B0	1387.0	1074.0
S4	-1193.0	-1853.0	VDD	1387.0	932.0
S5	-1326.0	-1853.0	T2	1387.0	792.0
S6	-1462.0	-1853.0	I7	1387.0	623.0
S7	-1849.0	-228.0	I6	1387.0	473.0
S8	-1849.0	-920.0	I5	1387.0	327.0
S9	-1849.0	420.0	I4	1387.0	177.0
S10	-1849.0	174.0	I3	1387.0	310.0
S11	-1849.0	305.0	I2	1387.0	-111.0
S12	-1849.0	438.0	I1(KSOUND)	1387.0	-264.0
S13	-1849.0	573.0	I0(KSTART)	1387.0	-417.0
S14	-1849.0	705.0	I8	1387.0	-576.0
S15	-1849.0	842.0	I9	1387.0	-726.0
S16	-1849.0	979.0	I10	1387.0	-857.0
PB	-590.0	1749.0	I11	1387.0	-1025.0
R0	-850.0	1749.0	VEE	1387.0	-1234.0
R1	-457.0	1749.0	VC1	1387.0	-1367.0
OO	640.0	1749.0	VC2	1387.0	-1503.0
OI	1144.0	1749.0	C4	1387.0	-1636.0
OI15P	1260.0	1749.0	C3	1343.0	-1853.0
T1	1383.0	1749.0	C2	1210.0	-1853.0
			C1	1081.0	-1853.0
			S28	948.0	-1853.0
			S27	816.0	-1853.0
			S26	684.0	-1853.0
			S25	546.0	-1853.0
			S24	412.0	-1853.0
			S23	280.0	-1853.0
			S22	146.0	-1853.0
			S21	120.0	-1853.0
			S20	-123.0	-1853.0
			S19	-258.0	-1853.0
			S18	-392.0	-1853.0
			S17	-589.0	-1853.0

Application Circuit

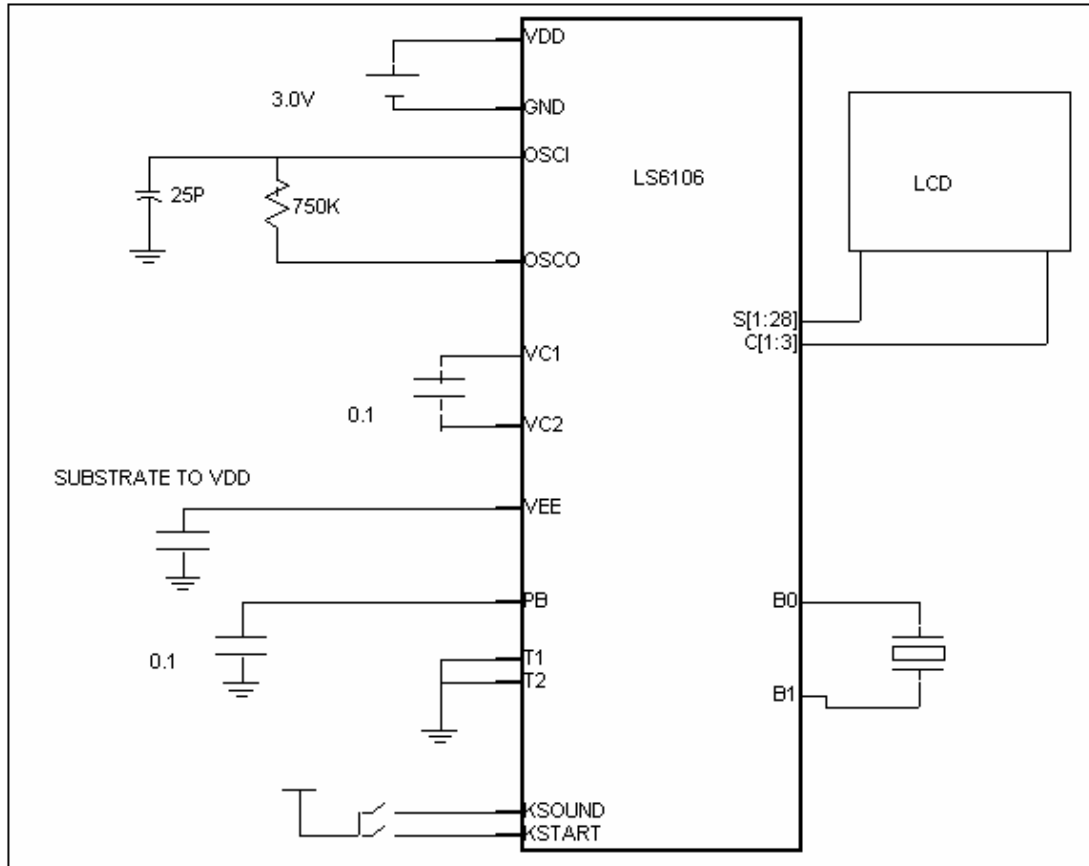

LCD Drawing

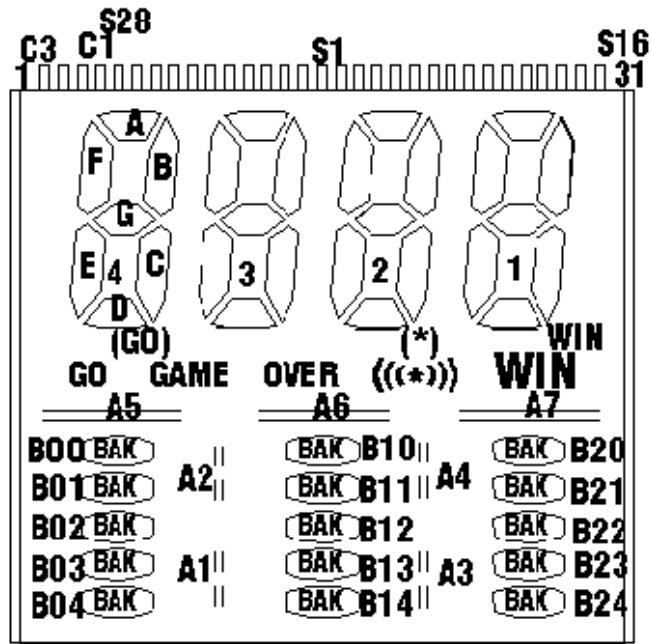

- Note:
1. Pin out at top of the LCD
 2. Twisted Nematic Display
 3. View Direction: 6 o'clock
 4. Polarizer : reflective/ positive
 5. Drive Method : 1/3 duty, 1/2 bias
 6. Operating Voltage : 3.0V
 7. Operating Temp. : 0 – 50C
 8. Connector : Zebra.

PIN | SIG | C1 | C2 | C3

1	C3			C3
2	C2		C2	
3	C1	C1		
4	S27	4F		4E
5	S26	4G	4A	4D
6	S25	4B		4C
7	S23	3F		3E
8	S22	3G	3A	3D
9	S21	3B		3C
10	S19	2F		2E
11	S18	2G	2A	2D
12	S17	2B		2C
13	S1	1F	GO	1E
14	S2	1G	1A	1D
15	S3	1B	WIN	1C
16	S5	A6	A5	A7
17	S6	B11	B01	B21
18	S7	A2		A4
19	S8	B12	B02	B22
20	S9	A1	(*)	A3
21	S10	B13	B03	B23
22	S11	B10	B00	B20
23	S12	B14	B04	B24