

Features:

- (a) Single 1.5V operating voltage.
- (b) Directly driving 2x14 segment LCD.
- (c) 3 display functions: Clock(12 hour format), date and second.
- (d) 32768 Hz quartz crystal provide the time base, and machine cycle = 4KHz.
- (e) Power on reset: When the power up, all LCD segments and the alarm sound are turned on for one second.
- (f) Programmable reset: When “ M ” key and “ S ” key press together, all LCD segments and it generates a sound(4KHz x 8Hz x 1Hz) with external trigger function. It will be stop and return to normal clock mode until release all keys..
- (g) Low power dissipation.
- (h) Key tone : It will generate a sound signal (tone) when only one key is pressed.
- (i) Bonding option to select total numbers of dots(3, 4, 5 and 6 dots)
- (j) Animation of dots with 3 bonding option :
 - One by one[off, 1, 2, 3, 4, 5, 6, off, 1, 2, 3,].
 - Accumulated[off, 1, 1+2, 1+2+3, 1+2+3+4, 1+2+3+4+5+6, off, 1, ..].
 - Special pattern[off, 1+2, 2+3, 3+4, 4+5, 5+6, off, 1+2, ...]
- (k) Keys: “ M ” --- Mode (mode and adjust), “ S ” --- setting.

General Description

The LS3263 is a single chip CMOS timer circuit with new animation watch I.C. It is designed to direct drive a LCD. The timer circuit is based on a 32768Hz quartz crystal controlled oscillator. An oscillator capacitor is build in the chip. An external 32768Hz quartz crystal is required to complete the oscillator circuit. The operation of the basic timekeeping functions is controlled via two keys. When power up reset, the clock will be reset to 1.1 12:00 and 00 seconds(12 hour format). The circuit has a built-in voltage doubler (to drive the LCD) which needs two external capacitors. Only one 1.5V battery is required to power the entire circuit.

LCD Drawing

PIN 1.....

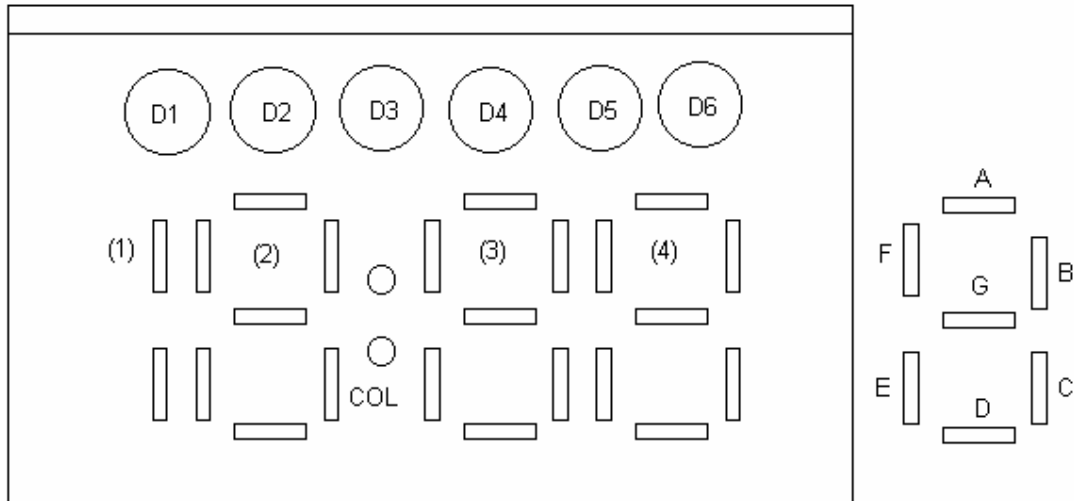

Functional Description

- (a) After the power on, it switch into clock state and shows "12:00" (12 hour format). The default value "1 Jan 12:00:00".
- (b) It shows 12 hour format and four group of "Hour/minute", "Alarm time", "Month/date", and "second". In clock state, "Hr : Min" is shown with colon flashing 0.5 sec on and 0.5 sec off. Press "M" key to indicate the "Alarm time" (if no key is pressed for 5 seconds, it will auto return to clock state "Hr : Min"), press "M" key again to indicate the "Month/date" (if no key is pressed for 5 seconds, it will auto return to clock state "Hr : Min"). Press again to show the "second". It can be clear by pressing "S" key. It will stay in second indication until return to clock state by pressing "M" key (the colon always on and not flash in second state, it only flash in clock state "Hr : Min").
- (c) In normal state, press "S" key into the clock setting state. The first setting is alarm option (alarm on/off or chime on/off), it can be change by pressing "M" key. Press "S" key to alarm hour setting, it can be set cycling from "12: A" (12 hour format) to "11: A" (12 hour format), "12: P" (12 hour format) to "11: P" (12 hour format) by pressing "M" key. Hold(2 sec) the "M" key will have auto advance. Press "S" key to alarm minute setting, it can be set from 0 to 59 by pressing "M" key. Hold (2 sec) the "M" key will have auto advance. Press "S" key to return normal mode (with alarm setting) or month setting (without alarm setting), it can be set from 1 to 12 by pressing "M" key. Hold (2 sec) the

6 Dot Animation 4 Digit Alarm Clock With Calendar

“M” key will have auto advance. Press “S” key to date setting, it can be set from 1 to 28/30/31(depend the month) by pressing “M” key. Hold (2sec) the “M” key will have auto advance. Press “S” key to hour setting, it can be set cycling from “12: A” (12 hour format) to “11: A” (12 hour format), “12: P” (12 hour format) to “11: P” (12 hour format) by pressing “M” key. Hold (2 sec) the “M” key will have auto advance. Press “S” key to minute setting, it can be set from “:00” to “:59” by pressing “M” key. Hold (2 sec) the “M” key will have auto advance. Press “S” key to return normal mode (without minute setting) or hold mode(with minute setting). In the hold mode, press “M” key only to return normal mode.

Pin Assignment

DESIGNATION	TYPE	DESCRIPTION
B [0:1]	OUTPUT	Buzzer output
V1, V2	OUTPUT	Doubler output
VEE	OUTPUT	-1.5V
T2, T1	INPUT (PL)	TEST pin
OO	OUTPUT	32KHz oscillator output
OI	INPUT	32KHz oscillator input
VDD	POWER	+1.5V power supply
GND	POWER	Ground
I[0:5]	INPUT(PH)	Input key/option
O[0:3]	OUTPUT	Trigger output (O[0:2])
C[1:2]	OUTPUT	LCD Common output
S[1:14]	OUTPUT	LCD Segment output

Note: (PL) – pull low
(PH) - pull high

Absolute Maximum Ratings

- Supply voltage Vdd - Vss.....0 to 5V
- Input voltage Vin.....Vss to Vdd
- Operating temperature Top-10°C to 60°C
- Storing temperature Tst-40°C to 70°C

***Comments**

Stress above those listed under Absolute Maximum Ratings” may cause permanent damage to the device. These are stress rating only. Functional operation of this device at these or any other conditions above those indicated in the operational sections of this specification is not implied and exposure to absolute maximum rating conditions for extended periods may affect device reliability.

6 Dot Animation 4 Digit Alarm Clock With Calendar

D.C. Electrical Characteristics

(GND = 0V, Vdd = 1.5V, Ta = 25°C unless otherwise specified)

Parameter	Symbol	Min.	Typ.	Max.	Unit	Conditions
Supply Voltage	Vdd	1.25	1.5	1.7	V	
Operating current	Idd	-	2	5	μA	No load
OSC. built-in cap	Cd	-	20	-	pF	
OSC. trimmer cap	Ctrim	5	-	35	pF	
Frequency stability	$\Delta f/f$	-	-	10	ppM	Vdd=1.6-1.4
Buzzer output current	Ib	500	-	-	μA	Vbd-Vss=0.5
LCD frequency	Flcd	-	64	-	Hz	
Segment current	Is	0.15	-	-	μA	Vseg=0.2V
Common current	Ic	3.0	-	-	μA	Vcom=0.2V
Trigger output current	Ir	100	-	-	μA	Vr-Vss=0.5

Pad location

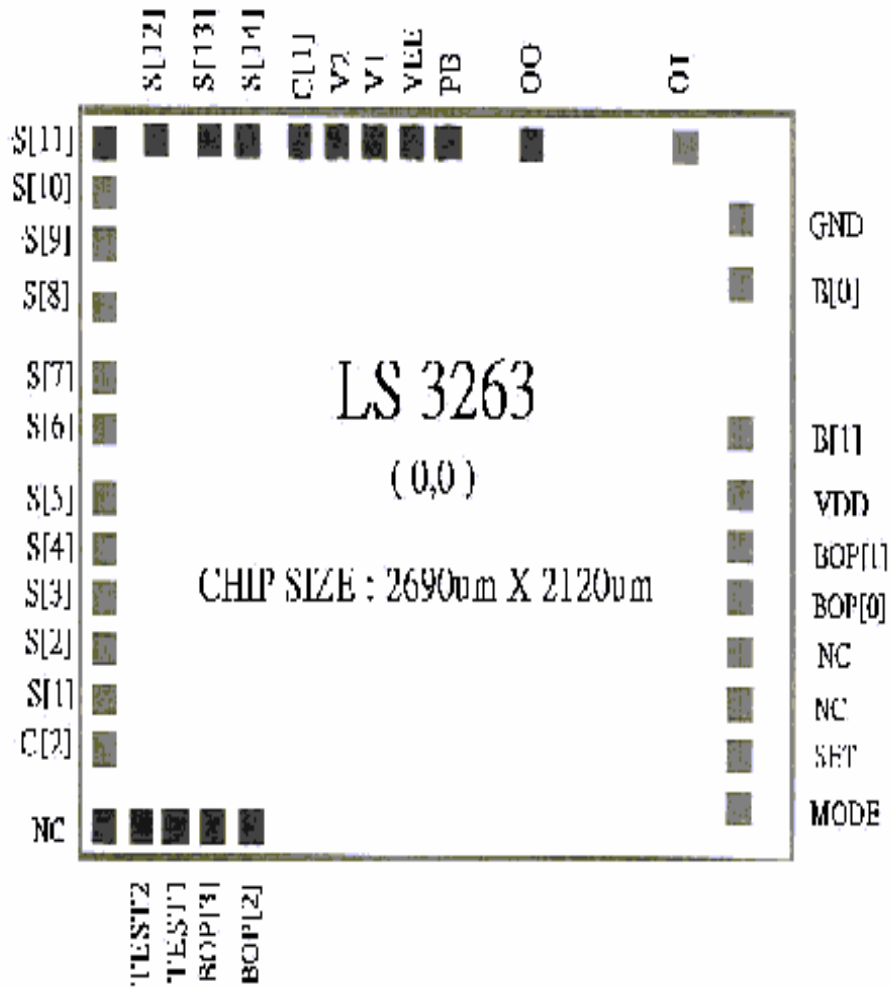

Pad Coordinate

PAD	X(μ m)	Y(μ m)	PAD	X(μ m)	Y(μ m)
BOP[2]	-667.0	-923.0	C[1]	-494.0	+923.0
BOP[3]	-802.0	-923.0	V2	-361.0	+923.0
TEST1	-937.0	-923.0	V1	-223.0	+923.0
TEST2	-1072.0	-923.0	VEE	-90.0	+923.0
NC	-1208.0	-923.0	PB	-47.0	+923.0
C[2]	-1208.0	-717.0	OO	+348.0	+916.0
S[1]	-1208.0	-582.0	OI	+901.0	+916.0
S[2]	-1208.0	-447.0	GND	+1098.0	+724.0
S[3]	-1208.0	-312.0	B0	+1098.0	+554.0
S[4]	-1208.0	-177.0	B1	+1098.0	+149.0
S[5]	-1208.0	-42.0	VDD	+1098.0	-20.0
S[6]	-1208.0	+149.0	BOP[1]	+1098.0	-156.0
S[7]	-1208.0	+285.0	BOP[0]	+1098.0	-294.0
S[8]	-1208.0	+476.0	NC[3]	+1098.0	-438.0
S[9]	-1208.0	+646.0	NC[2]	+1098.0	-576.0
S[10]	-1208.0	+781.0	SET	+1098.0	-720.0
S[11]	-1208.0	+916.0	MODE	+1098.0	-859.0
S[12]	-1012.0	+923.0			
S[13]	-821.0	+923.0			
S[14]	-686.0	+923.0			

Application Circuit

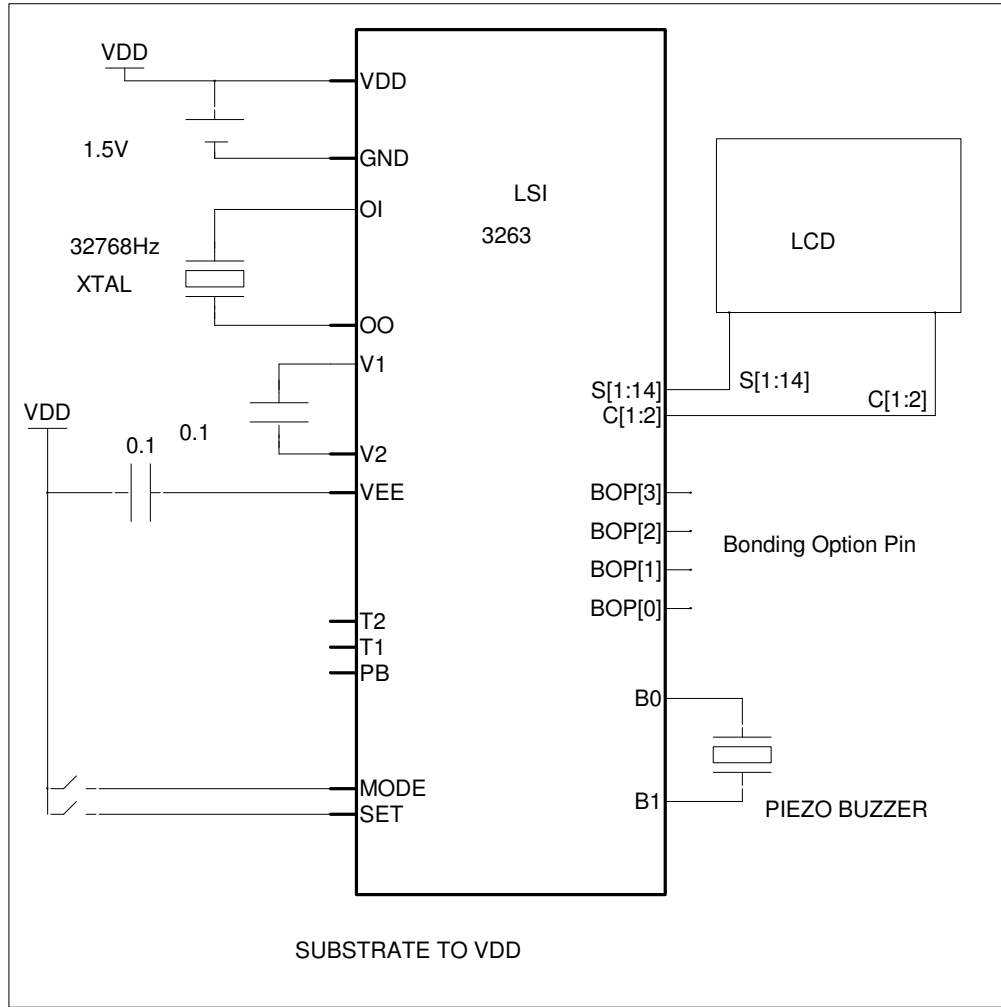

Bonding Option Pin: BOP[0] and BOP[1] to select total numbers of dots:

	BOP[1]	BOP[0]
D1, D2 and D3 (3 dots)	GND	GND
D1, D2, D3 and D4 (4 dots)	GND	VDD
D1, D2, D3, D4 and D5 (5 dots)	VDD	GND
D1, D2, D3, D4, D5 and D6 (6 dots)	VDD	VDD

Bonding Option Pin: BOP[2] and BOP[3] to select display pattern of dots:

	BOP[2]	BOP[3]
Accumulated mode	GND	VDD
Special Pattern mode	VDD	GND
One By One mode	VDD	VDD

Display dots in Accumulated mode

Stage1	All Dots Off.
Stage2	D1.
Stage3	D1 and D2.
Stage4	D1, D2 and D3.
Stage5	[D1, D2, D3 and D4] or [jump to stage1 (depend total number of dots option)].
Stage6	[D1, D2, D3, D4 and D5] or [jump to stage1 (depend total number of dots option)].
Stage7	[D1, D2, D3, D4, D5 and D6] or [jump to stage1 (depend total number of dots option)].
Stage8	jump to stage1.

Display dots in Special pattern mode

Stage1	All Dots Off.
Stage2	D1 and D2.
Stage3	D2 and D3.
Stage4	D3 and D4.
Stage5	[D4 and D5] or [jump to stage1 (depend total number of dots option)].
Stage6	[D5 and D6] or [jump to stage1 (depend total number of dots option)].
Stage7	jump to stage1.

Display dots in One By One mode

Stage1	All Dots Off.
Stage2	D1.
Stage3	D2.
Stage4	D3.
Stage5	[D4] or [jump to stage1 (depend total number of dots option)].
Stage6	[D5] or [jump to stage1 (depend total number of dots option)].
Stage7	[D6] or [jump to stage1 (depend total number of dots option)].
Stage8	jump to stage1.

LCD DRAWING

PIN 1.....

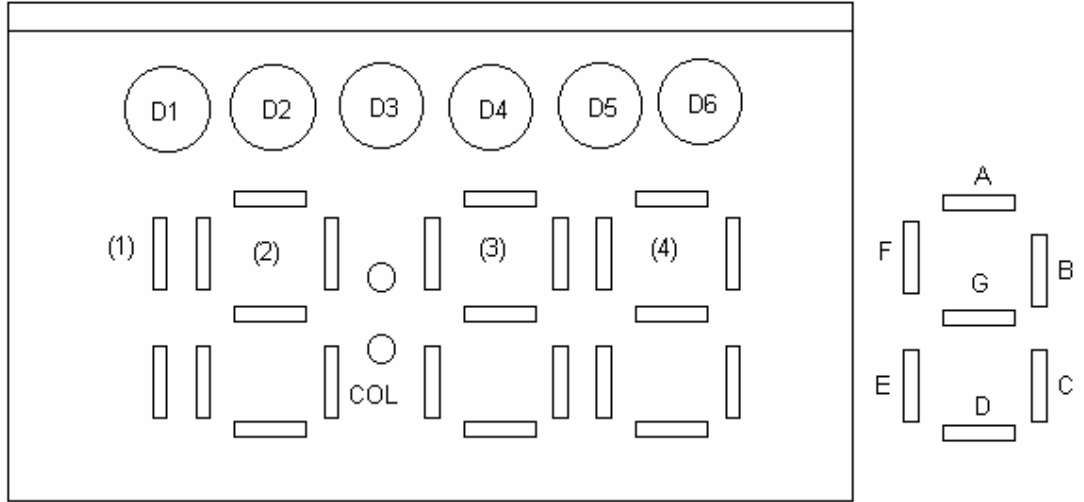

PIN	1	2	3	4	5	6	7	8	9	10	11	12	13	14	15	16
SEG	C2	S3	S4	S5	S6	S7	S8	S9	S10	S11	S12	S13	S2	S1	S14	C1
C1		D2	E2	G2	C2	E3	G3	C3	E4	G4	C4	D4	D2	D4	D6	COM1
C2	COM2	BC1	F2	A2	B2	F3	AD3	B3	F4	A4	B4	COL	D1	D3	D5	