

Features :

- * 6 digit (HH:MM SS) LCD display
- * Hour:Minute Second display
- * Month Date weekday display
- * Alarm with Chime
- * Dual time display
- * 2/3 keys operation
- * Auto Chime (8am-11pm only)
- * 12/24Hour display
- * 1/2 bias 1/3 duty LCD format
- * Built-in EL driver.
- * Very low power consumption
- * 32768 Crystal oscillator
- * Single 3.0V operation.

General Description

The LS6108 is a 6 digit LCD running second watch I.C. with Hour:Minute Second, Month Date weekday display. It support 12H/24 H display format and has a time alarm and hourly chime function. It has 2 or 3 keys operation : KD, KS, KR.

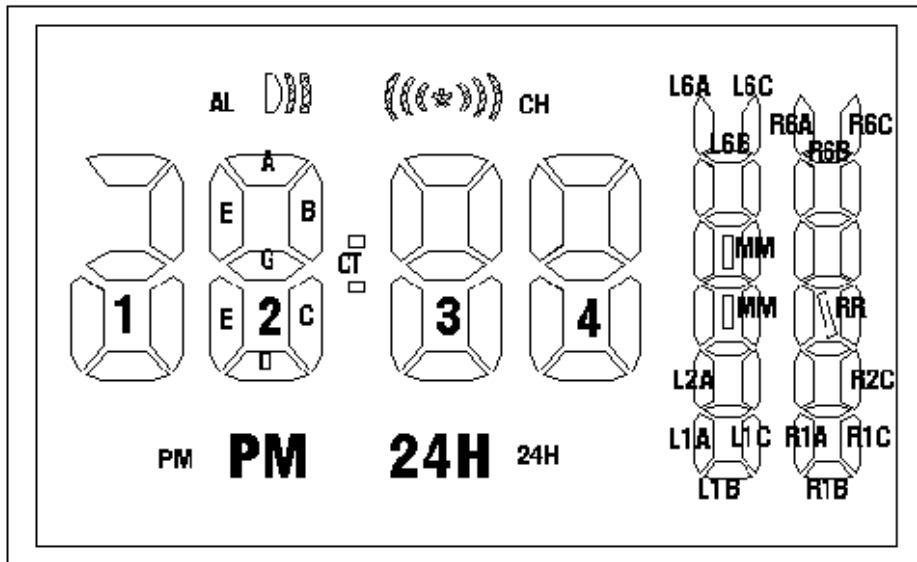

Bonding Option

The Scroll Second Speed can be selected by bonding option

BSP0	BSP1	Description
GND	GND	Fastest
VDD	GND	Fast
GND	VDD	Slow
VDD	VDD	Slowest

Operation

Key Operation

Press KD to change mode :

Time Mode => Date Mode => T2 Mode => Alarm Mode => Time Mode =>.....

At Time mode, press KR to toggle 12Hr or 24Hr display format.

At Time mode, press KS to enter setting mode:

- Time Mode
- ⇒ SET ALARM/CHIME ENABLE/DISABLE
 - ⇒ SET ALARM HOUR
 - ⇒ SET ALARM MINUTE => (Back to Time Mode if Alarm is adjusted)
 - ⇒ SET WEEKDAY
 - ⇒ SET MONTH
 - ⇒ SET DATE
 - ⇒ SET HOUR (**toggle between 12H/24H format every 24 hours)
 - ⇒ SET MINUTE
 - ⇒ RESET SECOND => (Back to Time Mode if Dual time is not selected)
 - ⇒ SET DUAL TIME HOUR (T2) (BDT option selected)
 - ⇒ Time Mode

- Press KD to adjust the setting value.
- In Setting Mode, press KR to exit from setting mode and go to Time Mode.
- If alarm time is adjusted, press KS will go to Time mode after setting ALARM MINUTE.
- SECOND can only be reset
- T2 can only set Dual time HOUR
- Hourly chime is active only from 8am to 11pm.

EL Output

EL driver output at R0, R1 is obtained if KEL is pressed.

The EL delay is around 2-3 second.

Pin Assignment

DESIGNATION	TYPE	DESCRIPTION
B [0:1]	OUTPUT	Buzzer output
VC1, VC2	OUTPUT	Halfer output
VEE	OUTPUT	Halfer voltage
T2, T1	INPUT (PL)	TEST pin
OO	OUTPUT	oscillator output
OI	INPUT	oscillator input
VDD	POWER	+3.0V power supply
GND	POWER	Ground
KS,KR,KD,KEL	INPUT(PL)	Input key/option
BSP0, BSP1	BONDING OPTION	Input /Output.
R[0:1]	OUTPUT	Output /EL output
C[1:4]	OUTPUT	LCD Common output
S[1:28]	OUTPUT	LCD Segment output

Note: (PL) – pull low
(PH) - pull high

Absolute Maximum Ratings

- Supply voltage Vdd - Vss.....0 to 5V
- Input voltage Vin.....Vss to Vdd
- Operating temperature Top-10°C to 60°C
- Storing temperature Tst-40°C to 70°C

***Comments**

Stress above those listed under "Absolute Maximum Ratings" may cause permanent damage to the device. These are stress rating only. Functional operation of this device at these or any other conditions above those indicated in the operational sections of this specification is not implied and exposure to absolute maximum rating conditions for extended periods may affect device reliability.

D.C. Electrical Characteristics

(GND = 0V, Vdd = 3.0V, Ta = 25°C unless otherwise specified)

Parameter	Symbol	Min.	Typ.	Max.	Unit	Conditions
Supply Voltage	Vdd	2.5	3.0	3.6	V	
Operating current	Idd	-	3	7	μA	No load
OSC. built-in cap	Cd	-	20	-	pF	
OSC. trimmer cap	Ctrim	5	-	35	pF	
Buzzer output current	Ib	500	-	-	μA	Vbd-Vss=0.5
LCD frequency	Flcd	-	64	-	Hz	
Segment current	Is	0.15	-	-	μA	Vseg=0.2V
Common current	Ic	3.0	-	-	μA	Vcom=0.2V
Trigger output current	Ir	100	-	-	μA	Vr-Vss=0.5

Pad Coordinate

PAD	X(μ m)	Y(μ m)	PAD	X(μ m)	Y(μ m)
C1	-1408.20	506.10	S26	942.20	-1513.90
S16	-1408.20	372.10	S27	1076.20	-1513.90
S15	-1408.20	238.10	S28	1210.20	-1513.90
S14	-1408.20	104.10	C3	1344.20	-1513.90
S13	-1408.20	-29.90	C2	1408.00	-1287.00
S12	-1408.20	-163.90	I4/BSP0	1408.00	-1151.00
S11	-1408.20	-297.90	I5/BSP1	1408.00	-741.60
S10	-1408.20	-431.90	I0/KM	1408.00	-597.60
S9	-1408.20	-565.90	I1/KR	1408.00	-188.20
S8	-1408.20	-699.90	I2/KEL	1408.00	-44.20
S7	-1408.20	-833.90	I3/KS	1408.00	365.20
S6	-1408.20	-967.90	VDD	1408.00	509.20
S5	-1408.20	-1101.90	B0	1408.00	653.20
S4	-1408.20	-1235.90	T2	1408.00	797.20
S3	-1408.20	-1369.90	T1	1408.00	941.20
S2	-1408.20	-1503.90	B1	1408.00	1085.20
S1	-570.50	-1513.90	GND	1408.00	1229.20
S17	-436.50	-1513.90	OI	1400.30	1423.00
S18	-238.70	-1513.90	OI 15pF	1400.30	1513.00
S19	-104.70	-1513.90	OO	184.00	1499.30
S20	93.10	-1513.90	R0	-56.30	1499.30
S21	227.10	-1513.90	R1	-425.20	1499.30
S22	406.20	-1513.90	PB	-561.20	1499.30
S23	540.20	-1513.90	VC1	-1045.70	1499.30
S24	674.20	-1513.90	VC2	-1179.70	1499.30
S25	808.20	-1513.90	VEE	-1313.70	1499.30

Pad Location

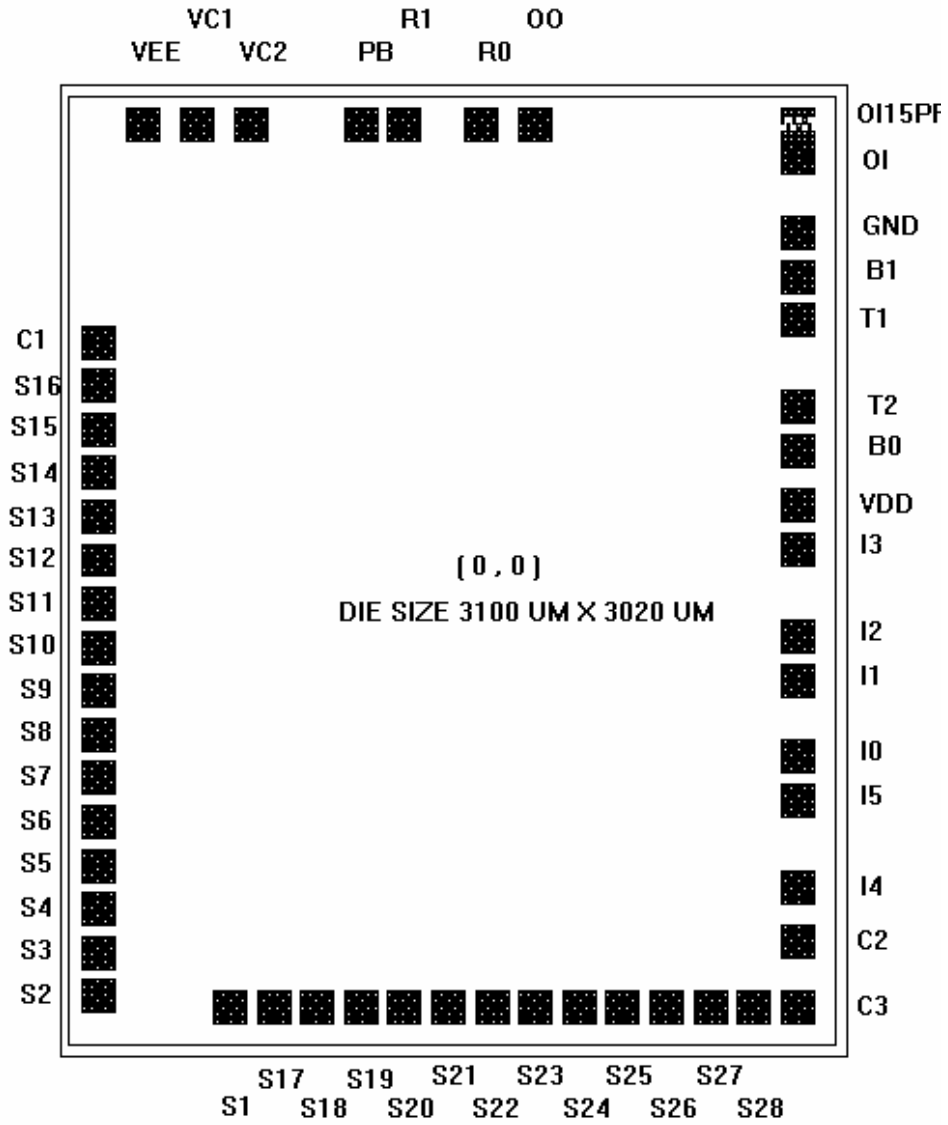

Application Circuit

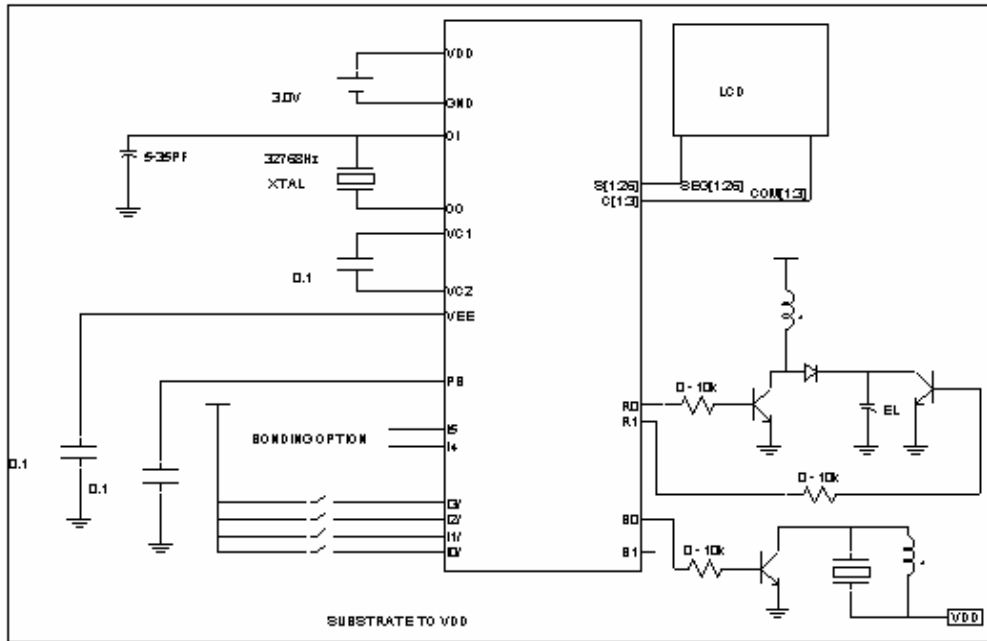

LCD Drawing

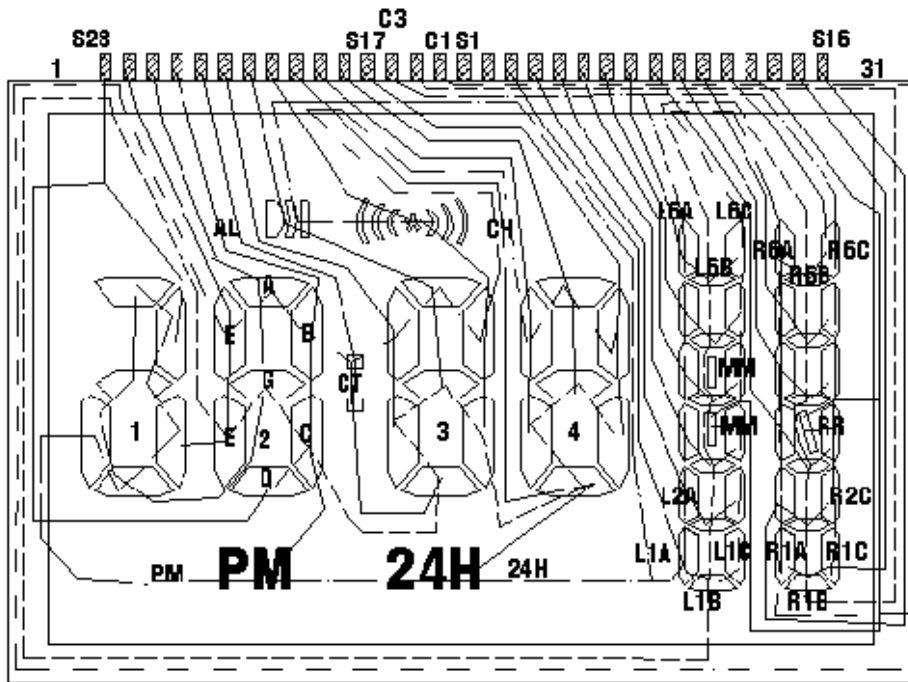
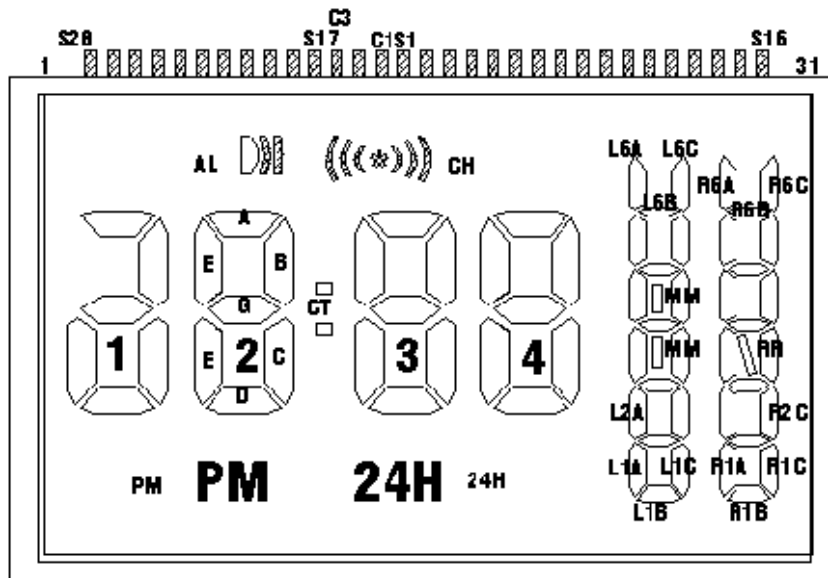

PIN	SIGNAL	C3	C2	C1	
1	Seg 28	1B	2D		
2	Seg 27	1C	2E	2F	
3	Seg 26	1ADEG	2G	2A	
4	Seg 25	PM	2C	2B	
5	Seg 24		3D	CT	
6	Seg 23		3E	3F	
7	Seg 22	AL	3G	3A	
8	Seg 21	CH	3C	3B	
9	Seg 20	H24	4D		
10	Seg 19		4E	4F	
11	Seg 18		4G	4A	
12	Seg 17		4C	4B	
13	COM 3	COM3			
14	COM 2		COM2		
15	COM 1			COM1	
16	Seg 1				
17	Seg 2				
18	Seg 3	L1A	L1B	L1C	
19	Seg 4	L2A	L2B	L2C	
20	Seg 5	L3A	L3B	L3C	
21	Seg 6	L4A	L4B	L4C	
22	Seg 7	L5A	L5B	L5C	
23	Seg 8	L6A	L6B	L6C	
24	Seg 9	R3C	R3B	R3A	
25	Seg 10	R4C	R4B	R4A	
26	Seg 11	R5C	R5B	R5A	
27	Seg 12	R6C	R6B	R6A	
28	Seg 13	RR		MM	
29	Seg 14				
30	Seg 15	R1C	R1B	R1C	
31	Seg 16	R2C	R2B	R2C	