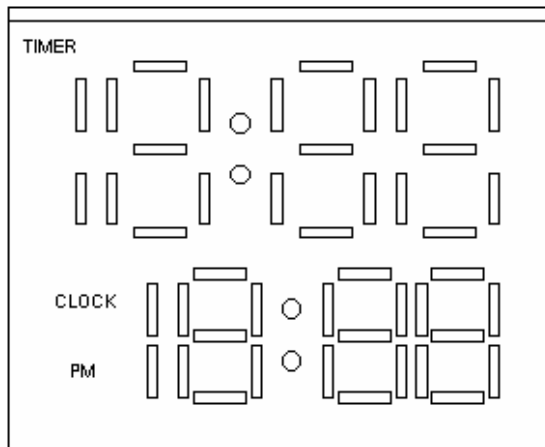

*Dual display Real time clock with Timer***Features**

- * Dual 3 1/2 digit (HH:MM) LCD display
- * Real time clock
- * 3/4 keys operation
- * Max. timer range 15Hour 59minute or 19Hour 59minute bonding option
- * 5minute, 10 minute pre-alarm
- * Trigger timer output
- * Recall Memory function
- * 1/2 bias 1/3 duty LCD format
- * Very low power consumption
- * 32768 Crystal oscillator
- * Single 1.5V operation.

General Description

The LSI6022 is a dual 3 1/2 digit LCD watch and timer I.C.. The I.C. display the timer/clock on the upper/lower display. The timer range can be selected between 15:59 or 19:59 by bonding option. It provides 10 minutes and 5 minutes pre-alarm. It can be used as a car park timer and kitchen timer. The timer can be selected with 20minutes count up by bonding option. The keytone can also be bonding option select.

LCD Drawing

DUAL DISPLAY

Functional Description

Counting Range

The LS6022 is a count down timer with 4 digit display HH:MM at the upper display and a real time clock at the lower display. The maximum count down range is 19 Hour 59 minutes or 15Hour 59 minutes selected by bonding option.

Four key operation

The LS6022 support 4 keys : KSET, KST, KHR, KMIN.

The LS6022 display the clock on the lower display and is always on. When the timer is in-active for 1 minute, the timer display(upper) is off. Press any of the KST, KHR, KMIN will wake up the timer.

When the timer is wake-up,
 Press KMIN to set the counting minute.
 Press KHR to set the counting hour.
 Press KST to start the count down.

When the system is counting, press Kstart will pause the counting.
 Press Kstart again to resume counting.

At any time, press KSET to enter set clock mode,
 Press KMIN to set the real time clock minute.
 Press KHR to set the real time clock hour.

System Reset

When KHR and KMIN is pressed simultaneously, the timer resets to 0:00.

Pre-alarm

At 10minutes, 5minutes before the alarm time, the system gives two pre-alarm signal.

Auto-off

When there is no activities for 1 minute, the system will automatically power off the LCD.
 Press any key will wake up the system again.

Bonding Option

There are 3 bonding option the control the LS6022, BKEYTONE, BUP, B1519

BKEYTONE	Description
VDD	With keytone
GND	No keytone

BUP	Description
VDD	20 minute count up at end of count
GND	Stop at 0 at end of count

B1519	Description
VDD	15 Hour
GND	19 Hour

Trigger output

When the timer counts down to 0, R0 will provide a trigger output. The output duration is 1 minute if no key is pressed during this 1 minute. The trigger output can be aborted by pressing any key during this 1 minute interval.

Pin Assignment

DESIGNATION	TYPE	DESCRIPTION
B0, B1	OUTPUT	Buzzer output
F512, VCAP	OUTPUT	Doubler output
VEE	OUTPUT	-1.5V
T1, T2, XT7, XT8, XT9, XT10, XT11	INPUT	TEST pin
COSCO	OUTPUT	32KHz oscillator output
COSCI	INPUT	32KHz oscillator input
VDD	POWER	+1.5V power supply
GND	POWER	Ground
BKEYTONE, B1519, BUP	INPUT(PH)	Bonding option
KST, KSET, KMIN, KHR	INPUT(PH)	Input key
PB	INPUT(PH)	Power up reset
C[1:3]	OUTPUT	LCD Common output
S[1:16]	OUTPUT	LCD Segment output

Note: (PH) - pull high;

Absolute Maximum Ratings

Supply voltage Vdd - Vss.....0 to 5V
 Input voltage Vin.....Vss to Vdd
 Operating temperature Top-10°C to 60°C
 Storing temperature Tst-40°C to 70°C

Comments

Stress above those listed under "absolute Maximum Ratings" may cause permanent damage to the device. These are stress rating only. Functional operation of this device at these or any other conditions above those indicated in the operational sections of this specification is not implied and exposure to absolute maximum rating conditions for extended periods may affect device reliability.

D.C. Electrical Characteristics

(GND = 0V, Vdd = 1.5V, Ta = 25°C unless otherwise specified)

Parameter	Symbol	Min.	Typ.	Max.	Unit	Conditions
Supply Voltage	Vdd	1.2	1.5	1.8	V	
Operating current	Idd	-	2	5	μA	No load
OSC. built-in cap	Cd	-	20	-	pF	
OSC. trimmer cap	Ctrim	5	-	35	pF	
Frequency stability	$\Delta f/f$	-	-	10	ppM	Vdd=1.6-1.4
Buzzer output current	Ib	500	-	-	μA	Vbd-Vss=0.5
LCD frequency	Flcd	-	64	-	Hz	
Segment current	Is	0.15	-	-	μA	Vseg=0.2V
Common current	Ic	3.0	-	-	μA	Vcom=0.2V

Pad Coordinate

PAD	X(μm)	Y(μm)	PAD	X(μm)	Y(μm)
GND	-1295.0	-1394.0	PB	-743.0	+1350.0
VCAP	-1295.0	-1251.0	R2	-593.0	+1350.0
VEE	-1295.0	-1110.0	R1	-449.0	+1350.0
V512	-1295.0	-965.0	R0	-225.0	+1350.0
C3	-1295.0	-825.0	OSCO	-75.0	+1350.0
C2	-1295.0	-685.0	OSCI	+1105.0	+1340.0
C1	-1295.0	-545.0	T1	+1246.0	+1340.0
S1	-1295.0	-400.0	GND1	+1246.0	+1140.0
S2	-1295.0	-260.0	B1	+1246.0	+988.0
S3	-1295.0	-120.0	B0	+1246.0	+678.0
S4	-1295.0	+20.0	VDD	+1246.0	+543.0
S5	-1295.0	+160.0	T2	+1246.0	+395.0
S6	-1295.0	+300.0	B1519	+1246.0	+226.0
S7	-1295.0	+440.0	BKEYTONE	+1246.0	+78.0
S8	-1295.0	+580.0	XT7	+1246.0	-70.0
S9	-1295.0	+720.0	BUP	+1246.0	-216.0
S10	-1295.0	+860.0	KSTART	+1246.0	-365.0
S11	-1295.0	+1000.0	KSET	+1246.0	-513.0
S12	-1295.0	+1140.0	KHR	+1246.0	-661.0
S13	-1303.0	+1350.0	KMIN	+1246.0	-809.0
S14	-1163.0	+1350.0	XT8	+1246.0	-957.0
S15	-1023.0	+1350.0	XT9	+1246.0	-1105.0
S16	-883.0	+1350.0	XT10	+1246.0	-1253.0
			XT11	+1246.0	-1400.0

Pad Location

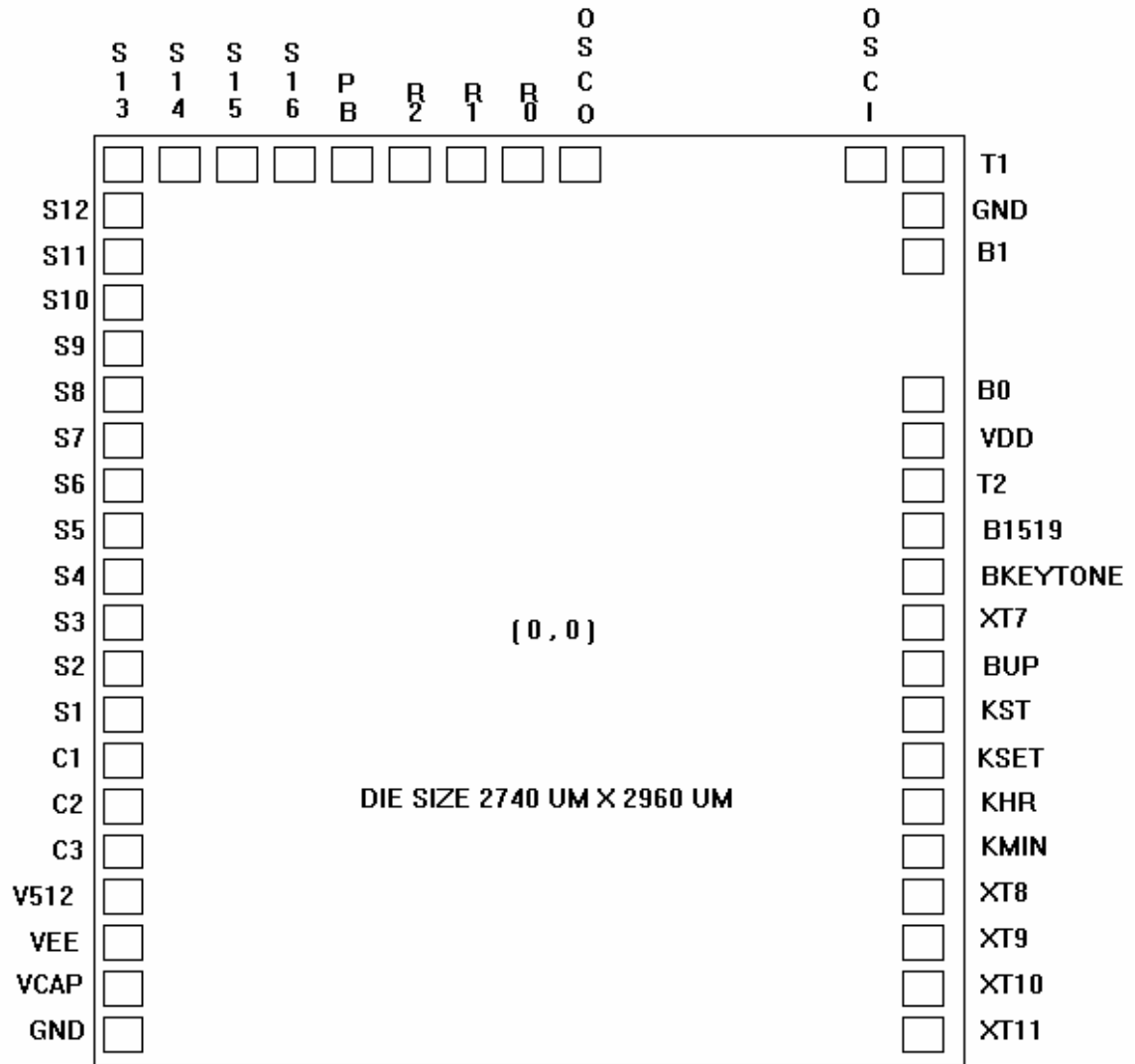

Application Circuit

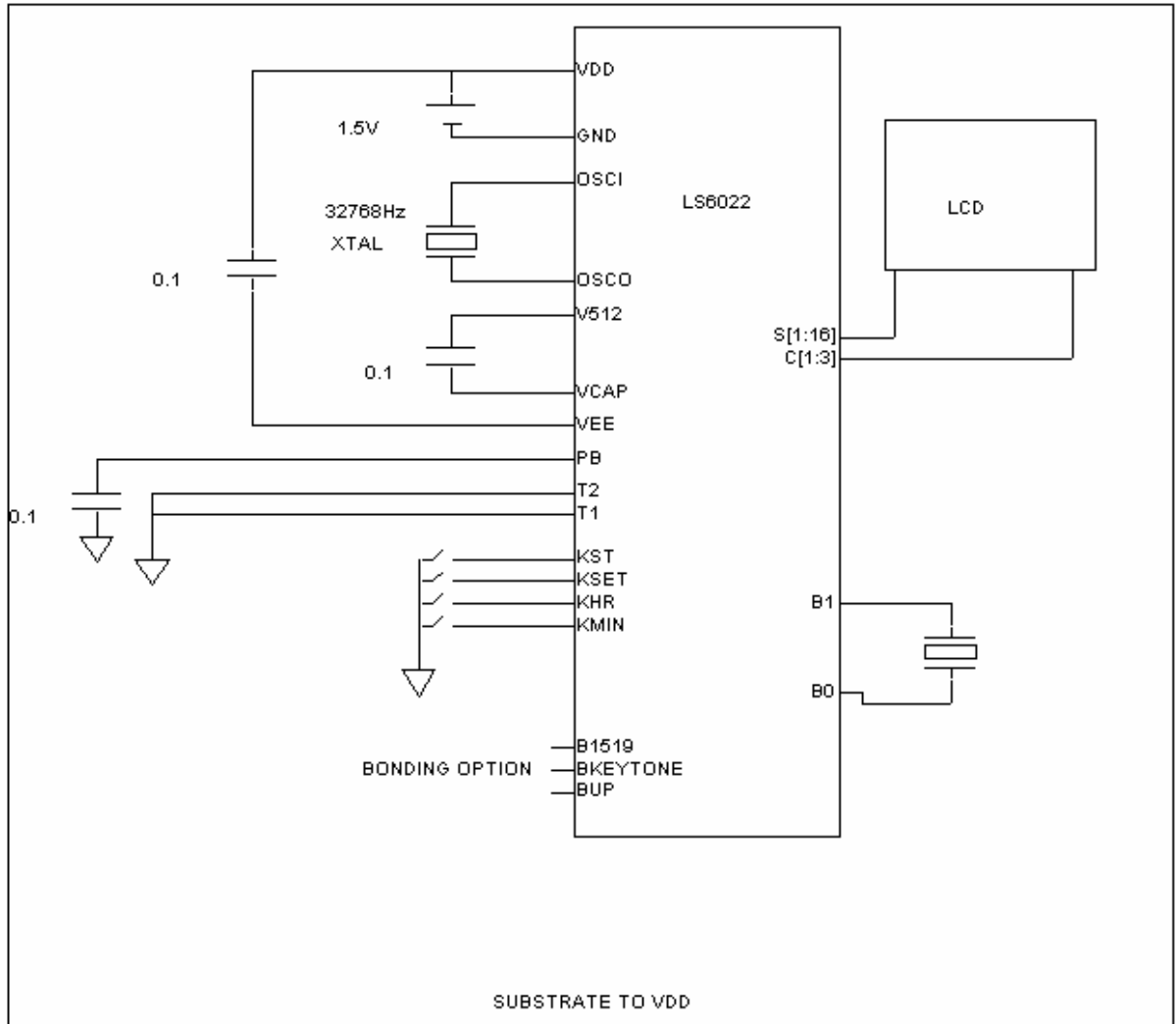

LCD Drawing

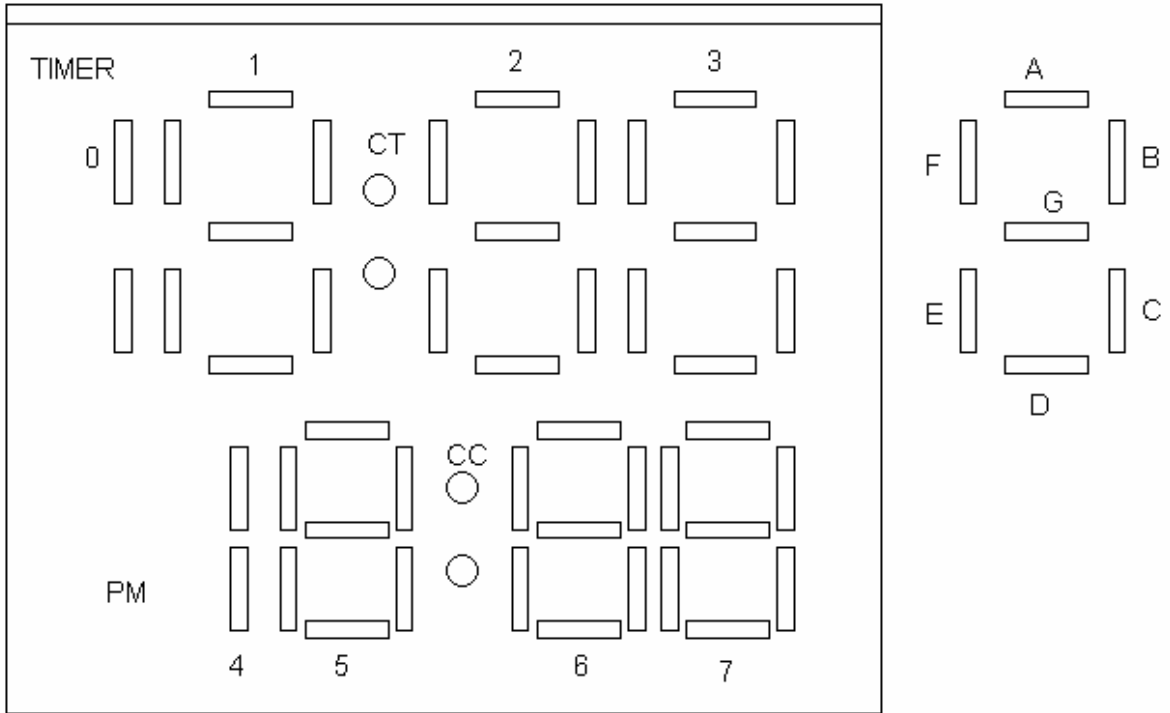

S16	S15	S14	S13	S12	S11	S10	S9	S8	S7	S6	S5	S4	S3	S2	S1
COM1:3B	3G	3C	3D	2B	2G	2C	2D	1B	1G	1C	1D	5B	5G	5C	5D
COM2:3A	3F	3E	OFF	2A	2F	2E	CT	1A	1F	1E	0BC	5A	5F	5E	4BC
COM3:7D	7C	7G	7B	7A	7F	7E	TIM	6C	6B	6AD	CC	6F	6G	6E	PM